

**Plan View**

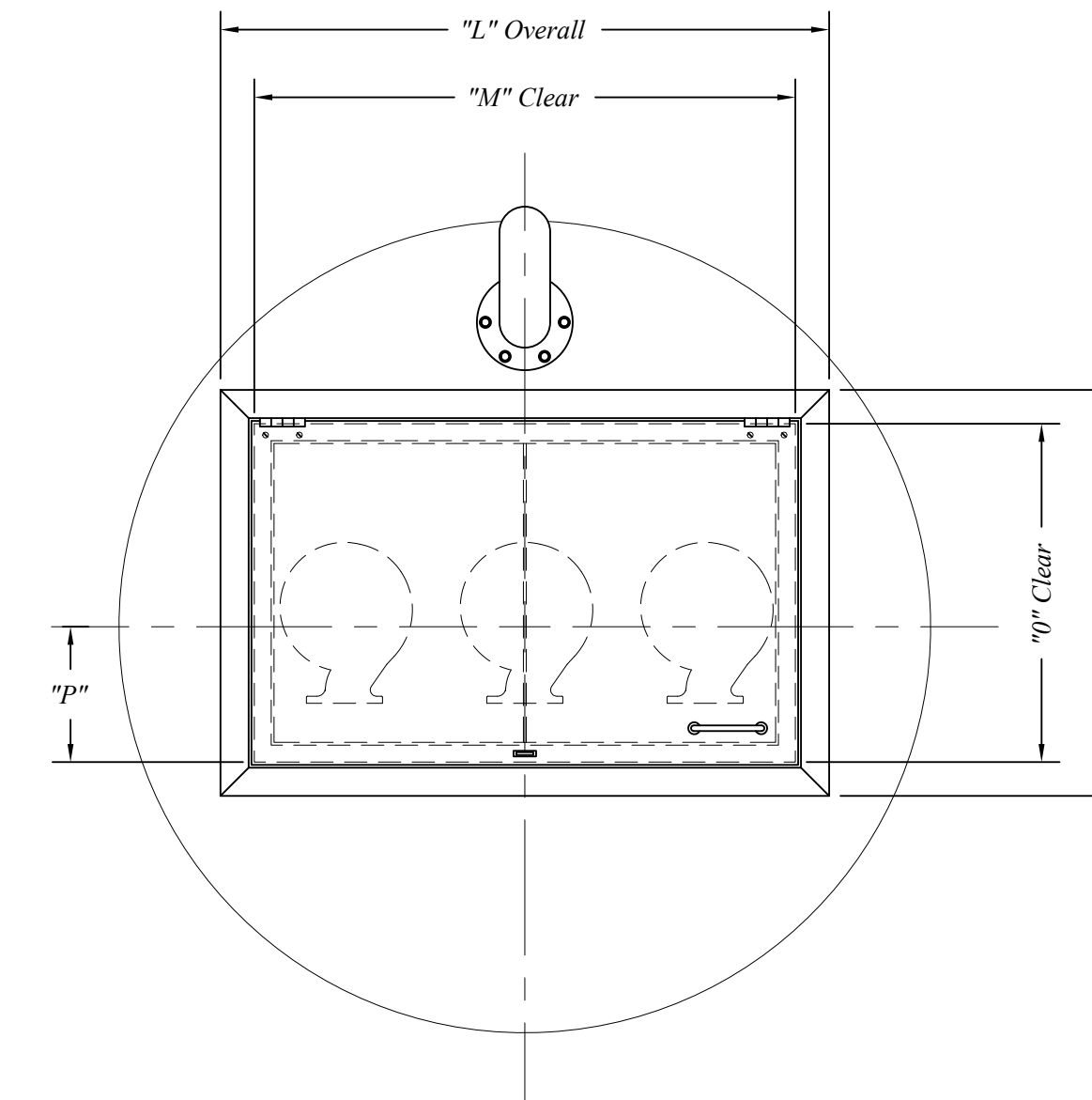

**Profile View**

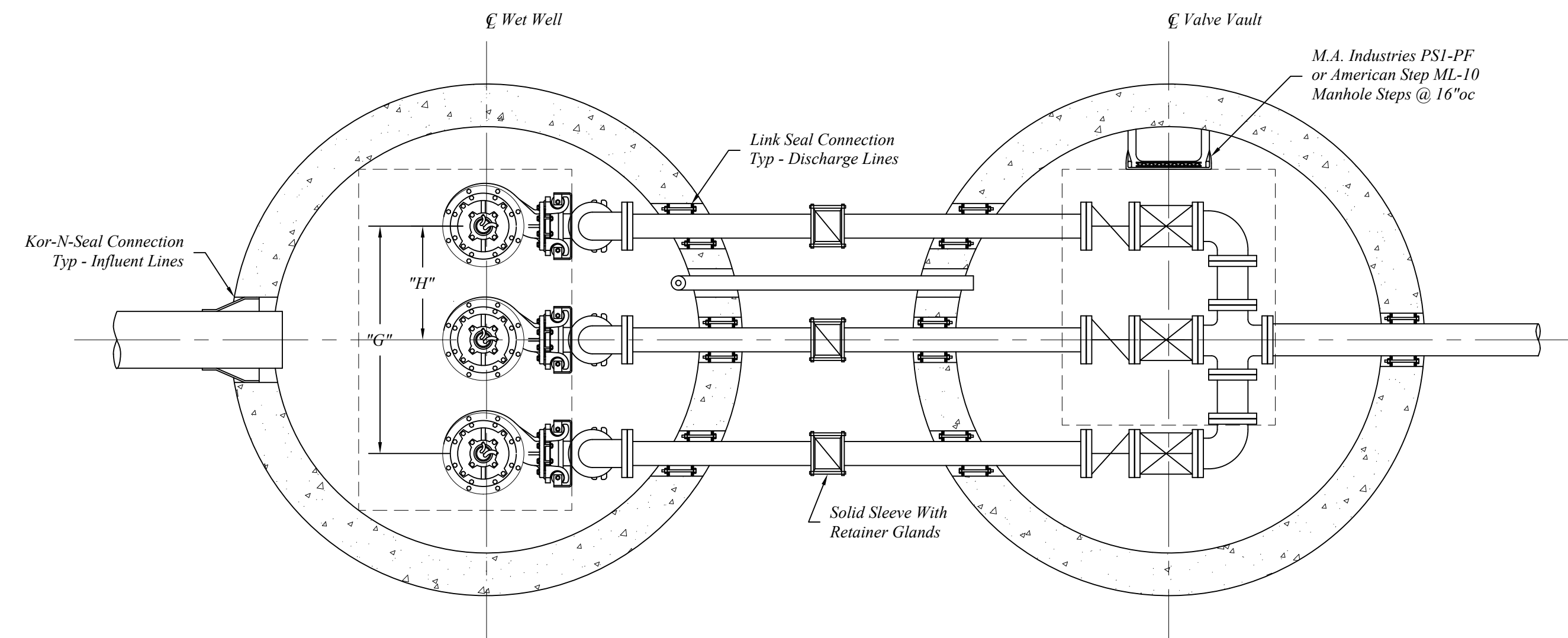
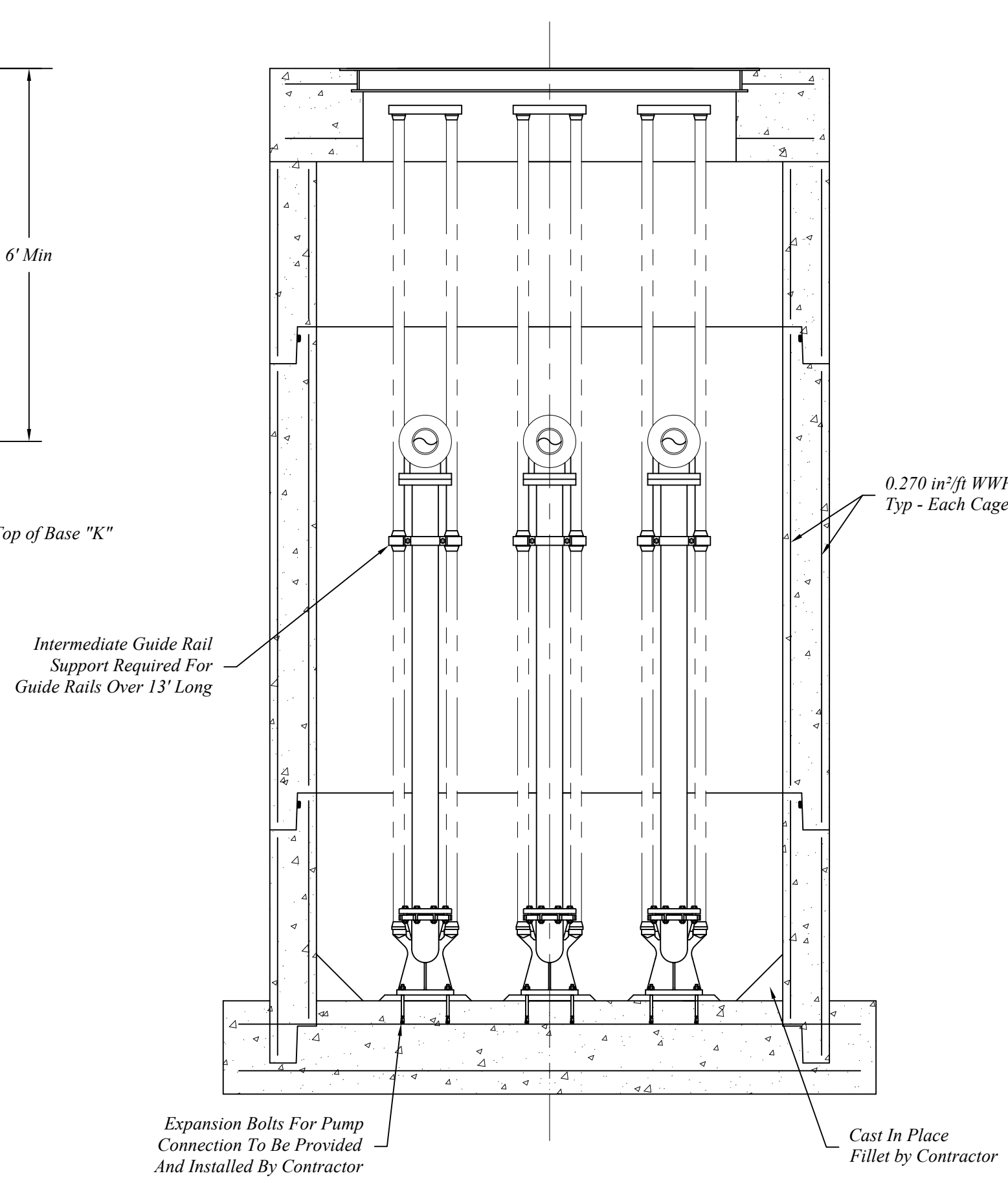
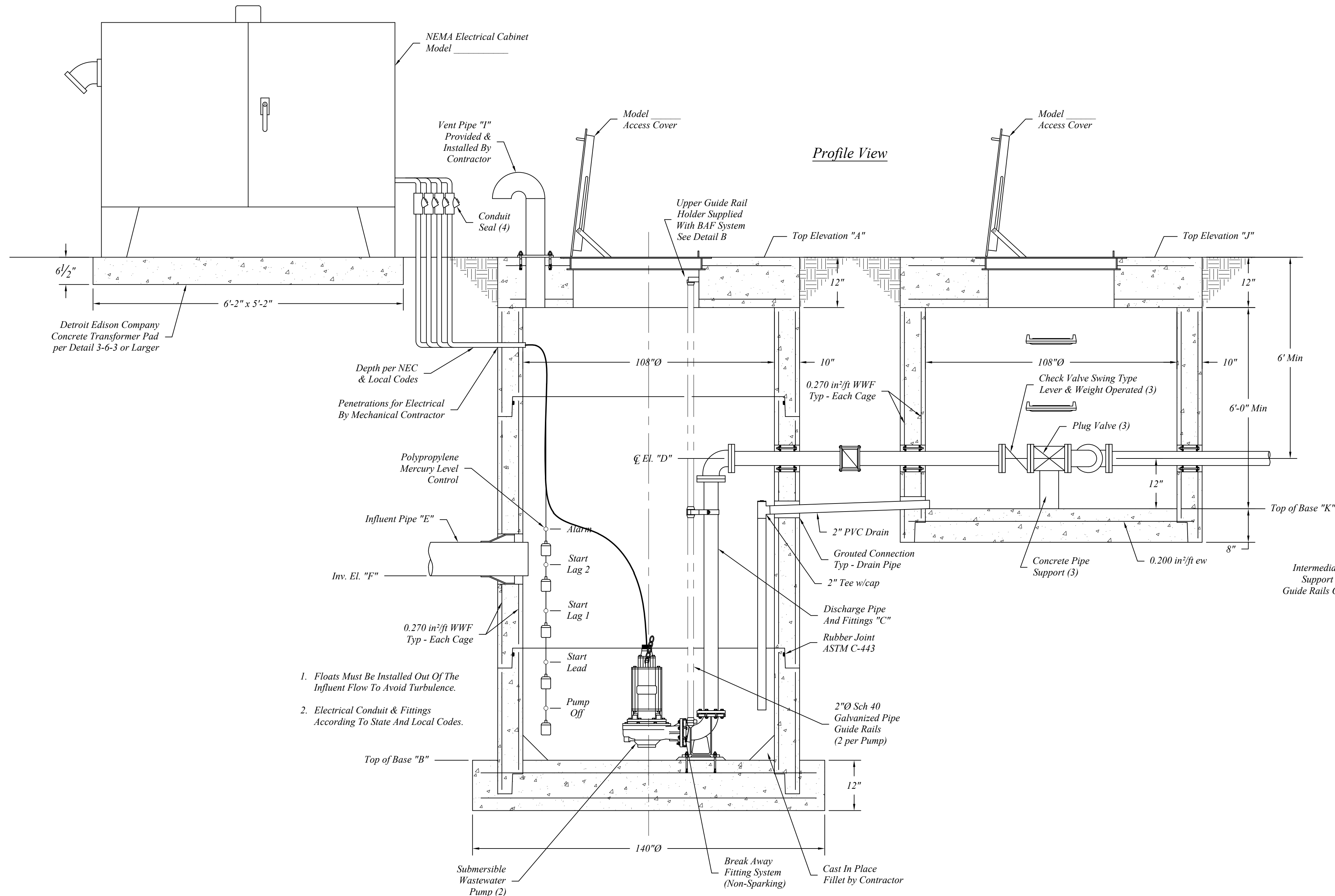

**Precast Notes:**  
 Pump Station Sections To Be Manufactured To ASTM C-478 Specifications w/HIS-20 Loading.  
 Manufactured as per Northern Concrete Pipe, Inc. (1.800.222.9918) or approved equal.  
 Concrete: 4000 psi @ 28 Days.  
 Reinforcement per ASTM A-615 & A-496.

Wet Well Dimensions	
A	Top of Cover Elevation
B	Top of Base Elevation
C	Discharge Pipe Diameter
D	Discharge Pipe $\bar{C}$ Elevation
E	Influent Pipe Diameter
F	Influent Pipe Inv. Elevation
G	Discharge Line Spacing
H	Discharge Line Offset
I	Vent Pipe Diameter
Wet Well Cover Reinforcing # Bars @ " oc, ew	
Wet Well Base Reinforcing # Bars @ " oc, ew	
Valve Vault Dimensions	
J	Top of Cover Elevation
K	Top of Base Elevation
Valve Vault Cover Reinforcing # Bars @ " oc, ew	
Wet Well Access Hatch Dimensions	
L	Access Hatch Overall Length
M	Access Hatch Clear Length
N	Access Hatch Overall Width
O	Access Hatch Clear Width
P	Access Hatch Offset
Pump Specifications	
Pump Model Number	
Gallons per Minute (GPM)	
Total Dynamic Head (TDH)	
Horse Power (HP)	
Phase	
Voltage (V)	
Alarm Elevation	
Lag Pump 2 Elevation	
Lag Pump 1 Elevation	
Lead Pump Elevation	
Pump Off Elevation	

