



Precast Handhole Will Weigh
Approximately 1,140 Lbs.

Precast Handhole To Be
Manufactured To ASTM C-478
Specifications w/HS-25 Loading.

Concrete Strength: 4500 psi @
28 days.

MDOT Grade S2 Concrete In
Accordance w/Section 701.

Reinforcing Per ASTM A-185 or
A-497 For WWF & ASTM A-615
Grade 60 for Rebar.

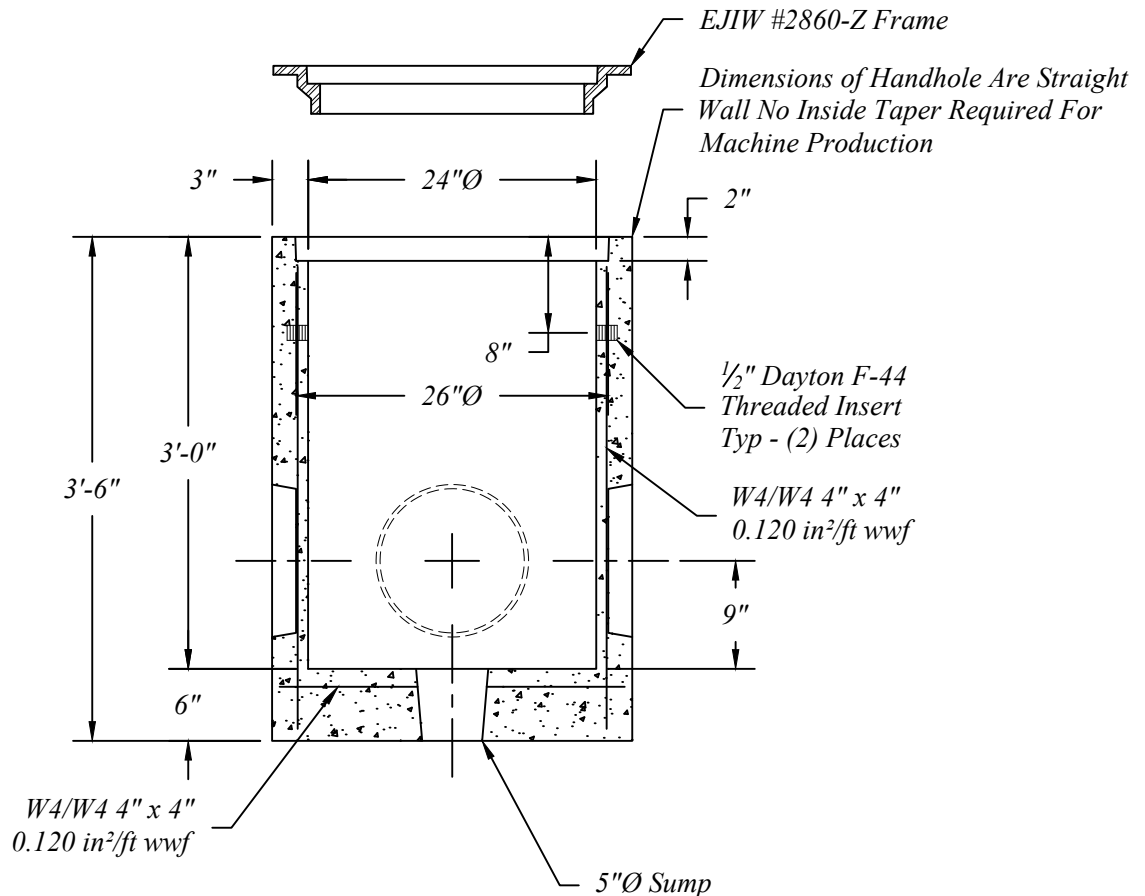
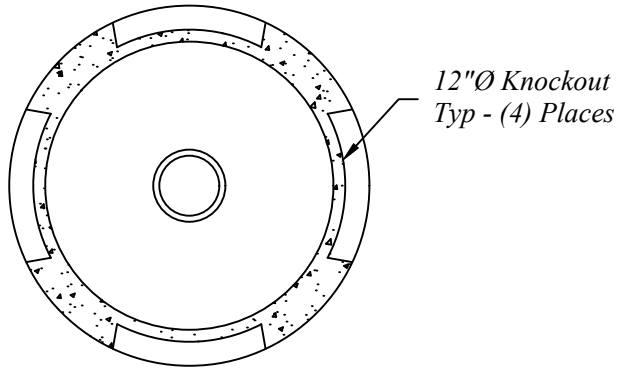

NORTHERN CONCRETE PIPE



401 Kelton St Bay City, MI 48706

5281 Lansing Rd
Charlotte, MI 48813

4950 White Lake Rd
Clarkston, MI 48346

2701 Chicago Dr SW
Wyoming, MI 49519

3756 Centennial Rd
Sylvania, OH 43560

Proposed - 24"Ø x 3'-0" Precast MDOT Handhole

Date
10 May 16

Revised
10 May 18

Rev. No.

Drawn By
BmG

Scale
NTS

08.17