



Precast Handhole Will Weigh Approximately 1,675 Lbs.

Precast Handhole To Be Manufactured To ASTM C-478 Specifications w/HS-20 Loading.

Reinforcing To Meet ASTM A-615 Specifications, Grade 60 Rebar.

Concrete Strength To Be 4,500 psi @ 28 Days.

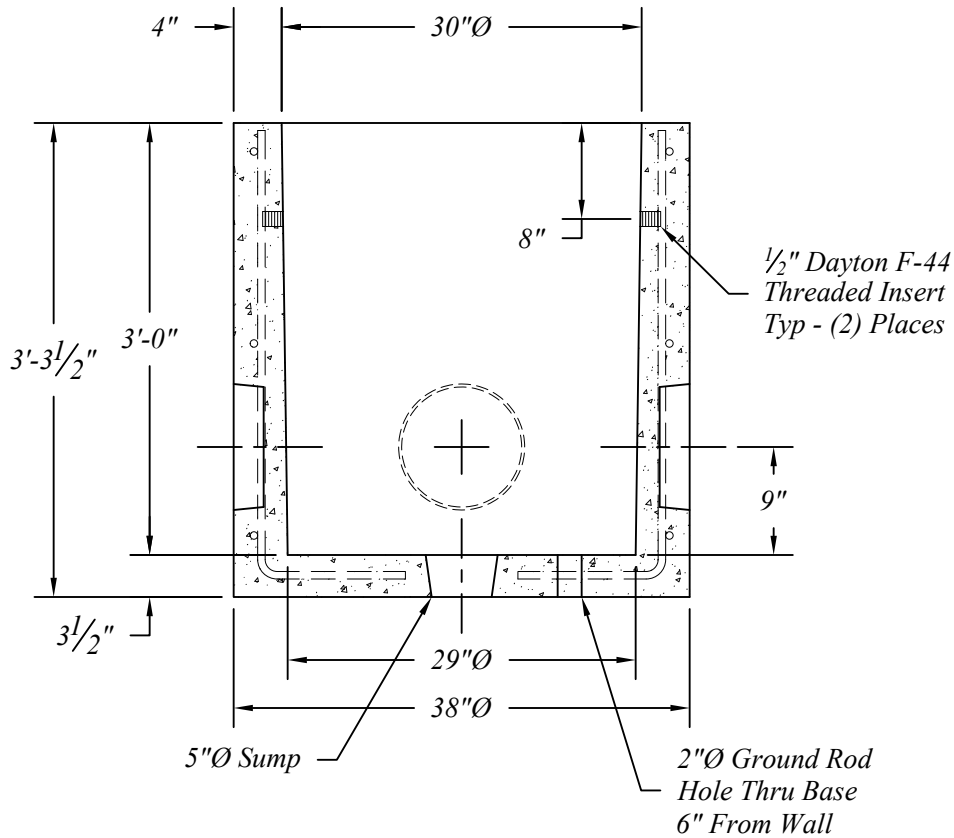
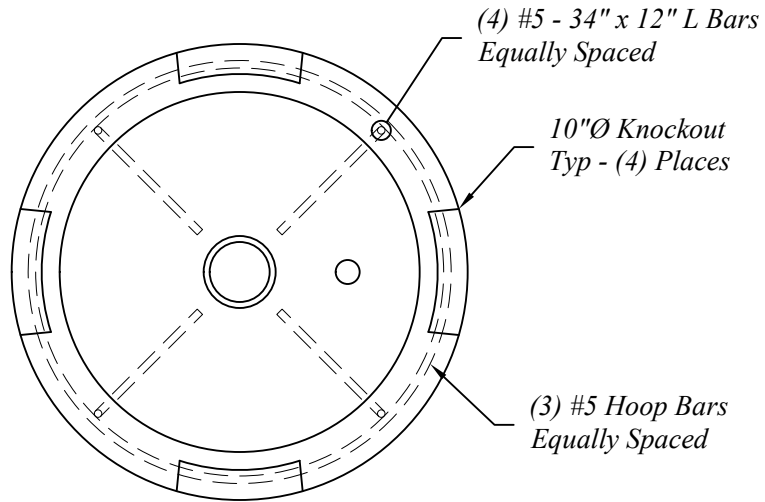

NORTHERN CONCRETE PIPE



401 Kelton St Bay City, MI 48706

5281 Lansing Rd
Charlotte, MI 48813

4950 White Lake Rd
Clarkston, MI 48346

2701 Chicago Dr SW
Wyoming, MI 49519

3756 Centennial Rd
Sylvania, OH 43560

Proposed - 30"Ø x 3'-0" Precast MDOT Handhole

Date 10 May 16

Revised

Rev. No.

Drawn By BmG

Scale NTS

08.16