

Pipe & Riser Section To Be Cut To Shape When Cast. Riser To Be Set On Mainline Section, Exposed Reinforcing Fabric Of Each Piece To Be Lapped And Welded. Area Of Exposed Reinforcing Mesh To Be Filled And Finished With Speed-Crete Or Equal.

Rubber Joint
ASTM C-443

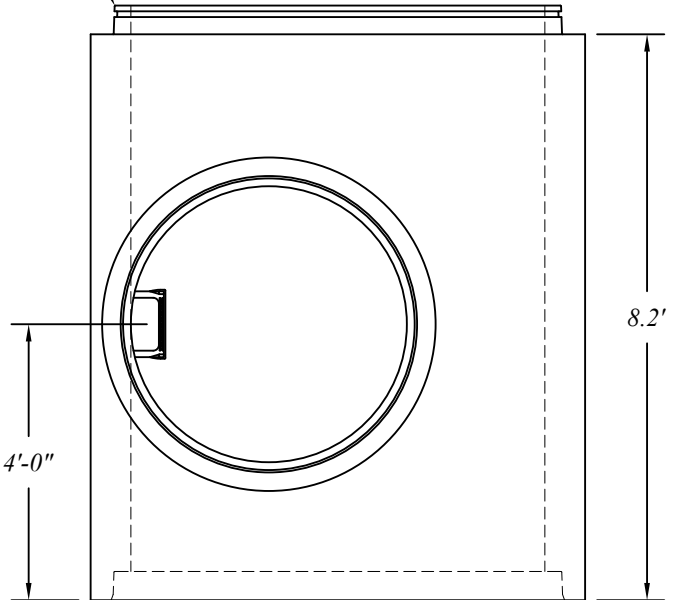

48" Riser Cut To
Shape When Cast

Rubber Joint
ASTM C-443

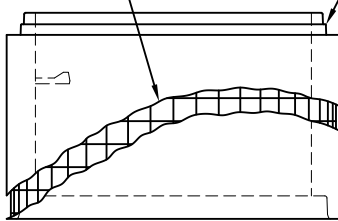

5" 48"Ø ±9"

Mainline Pipe Cut To
Shape When Cast

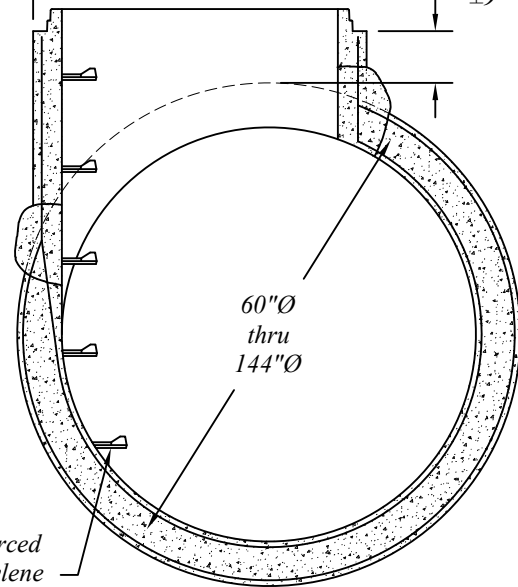
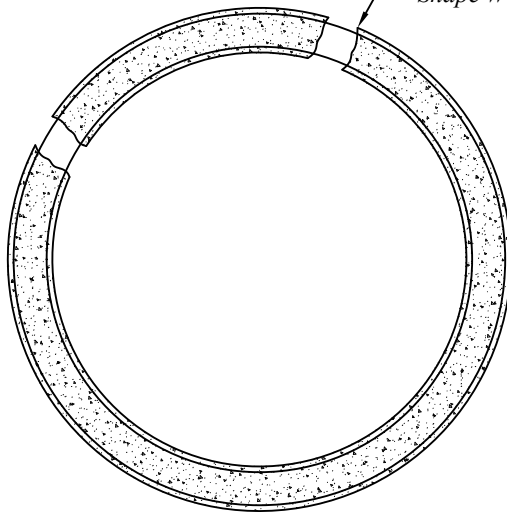

Steel Reinforced
Polypropylene
MH Steps @ 16"oc

Pipe Manufactured To ASTM C-76
Specifications, Reinforcing Class As Required.

48" Manhole Riser Manufactured To ASTM
C-478 Specifications.

Reinforcing Shown For Schematic Only.

60"Ø Thru 144"Ø Prefabricated Eccentric Manhole Tee



401 Kelton St Bay City, MI 48706

Date
12 May 16

5281 Lansing Rd
Charlotte, MI 48813

2701 Chicago Dr SW
Wyoming, MI 49519

Drawn By
BmG

4950 White Lake Rd
Clarkston, MI 48346

3756 Centennial Rd
Sylvania, OH 43560

Scale
NTS

05.06