

Plan View

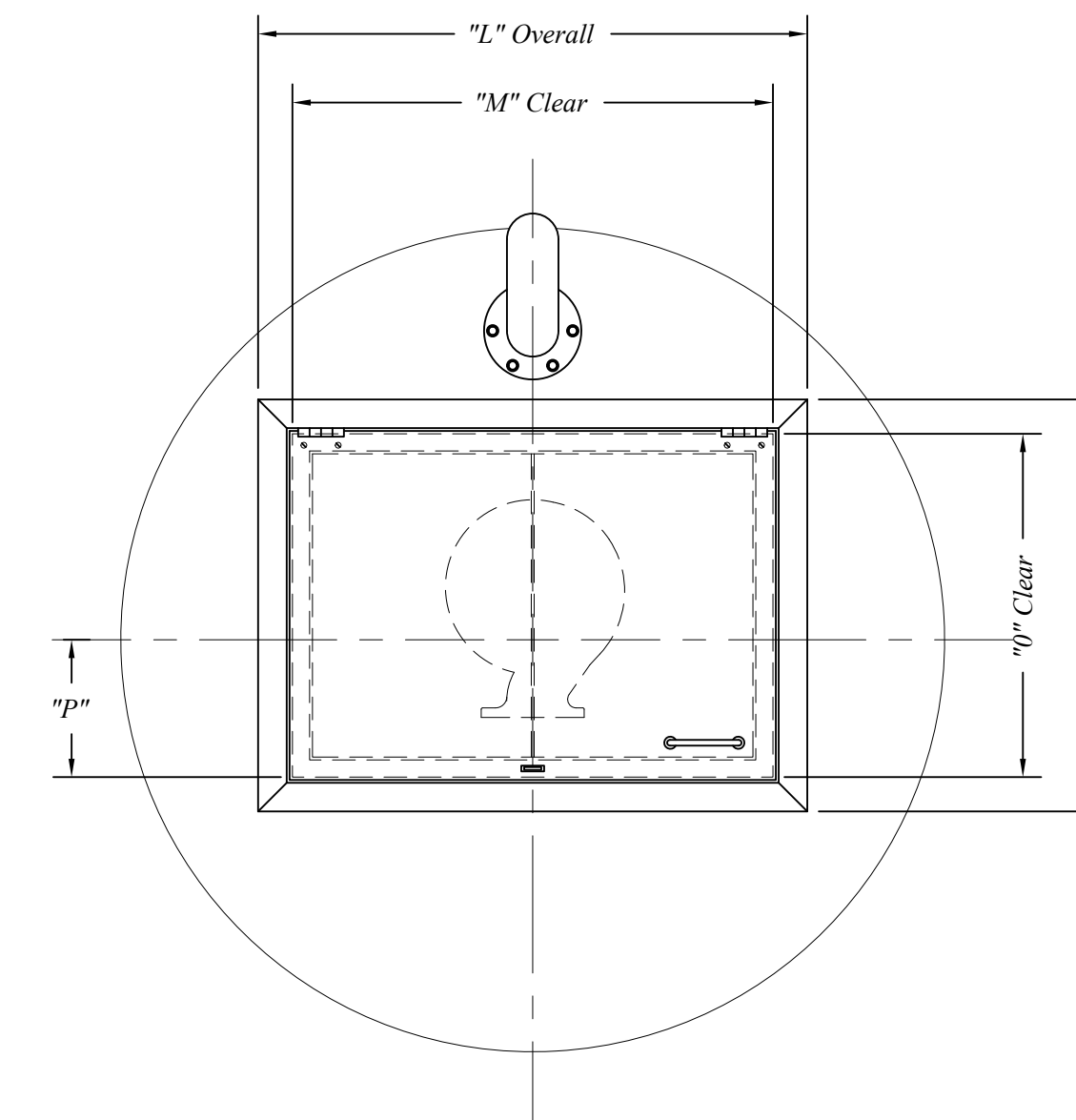

Profile View

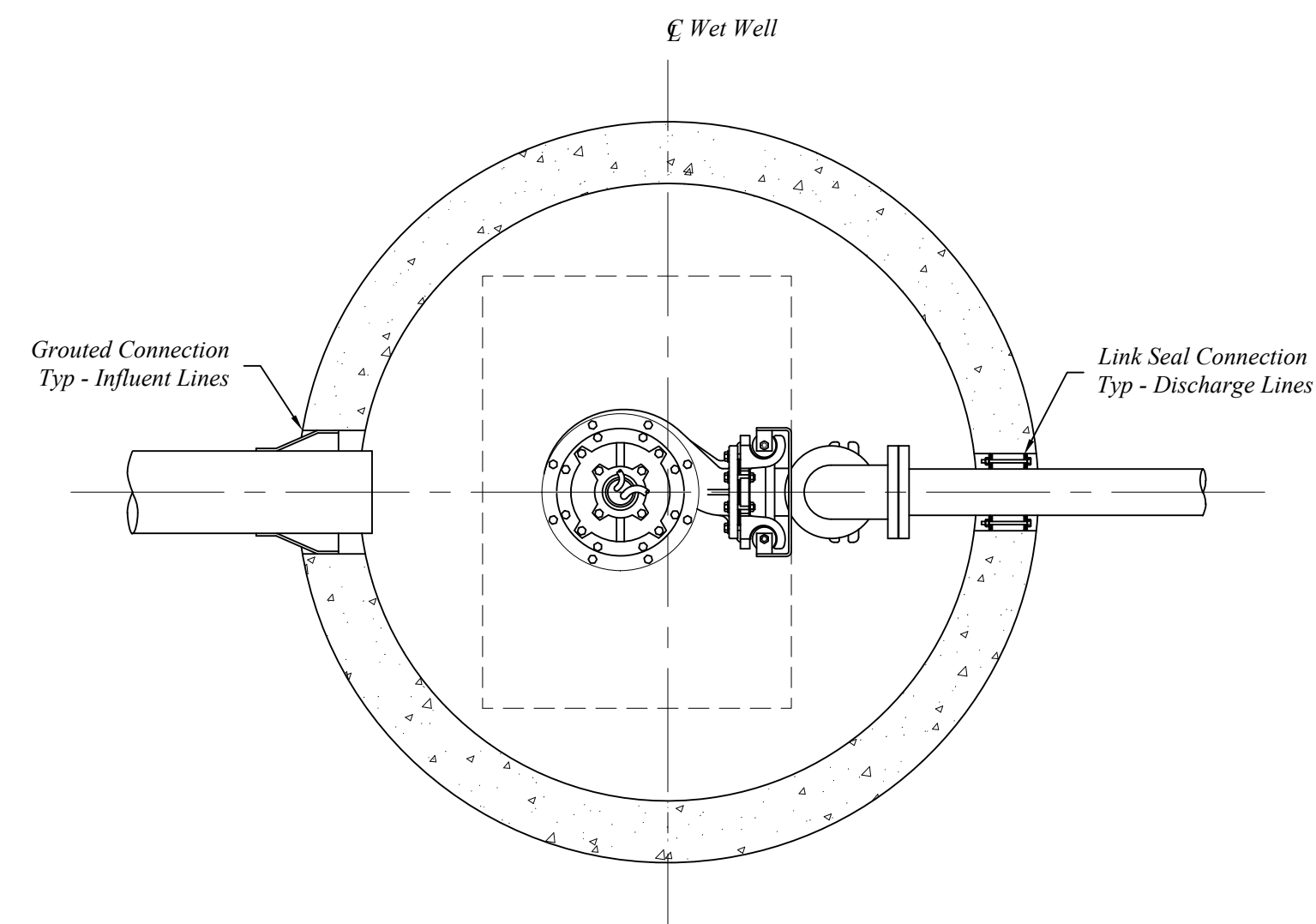
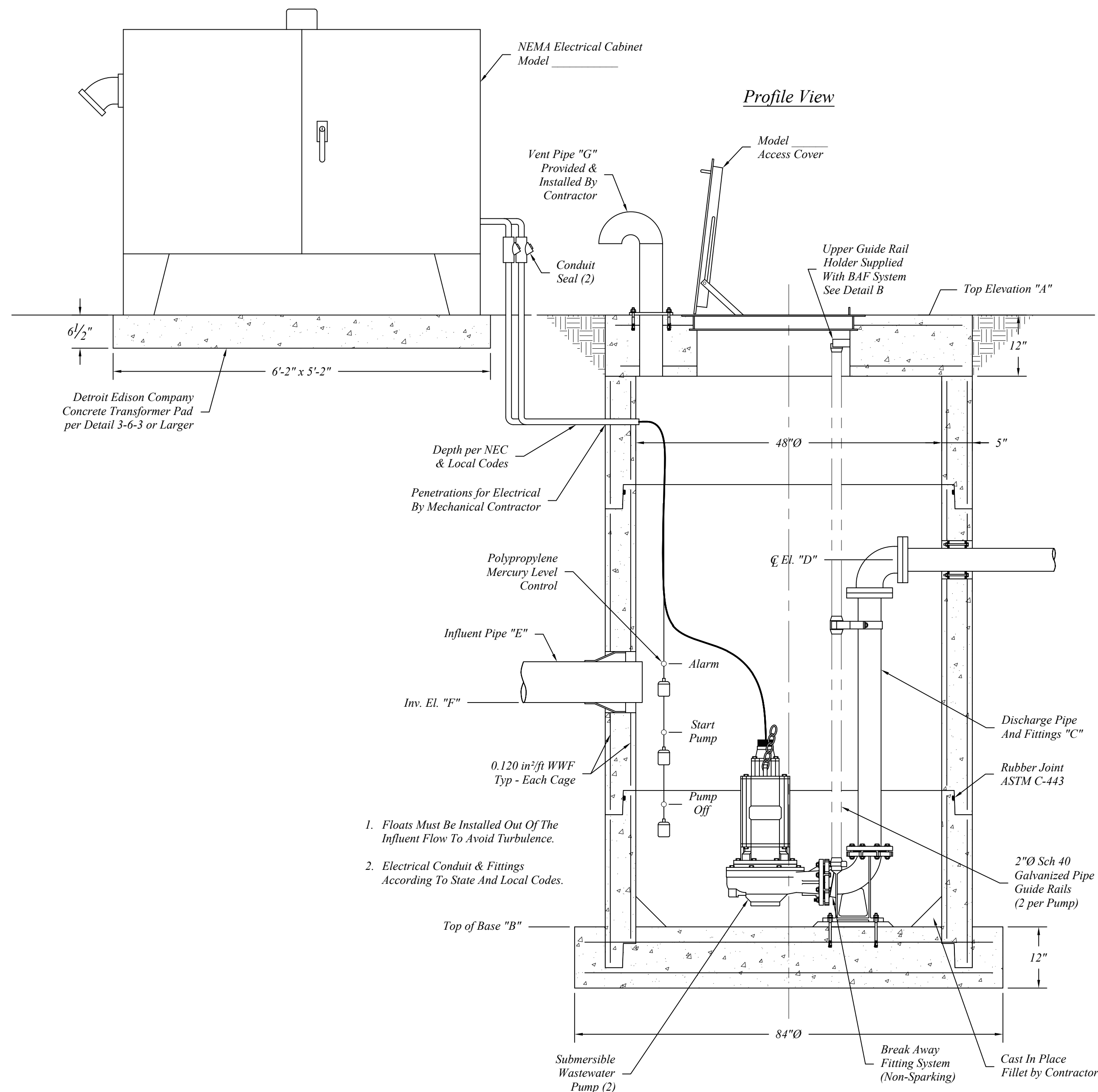

Precast Notes:

Pump Station Sections To Be Manufactured To ASTM C-478 Specifications w/HIS-20 Loading.

Manufactured as per Northern Concrete Pipe, Inc. (1.800.222.9918) or approved equal.

Concrete: 4000 psi @ 28 Days.

Reinforcement per ASTM A-615 & A-496.

Wet Well Dimensions	
A	Top of Cover Elevation
B	Top of Base Elevation
C	Discharge Pipe Diameter
D	Discharge Pipe ϕ Elevation
E	Influent Pipe Diameter
F	Influent Pipe Inv. Elevation
G	Vent Pipe Diameter
	Wet Well Cover Reinforcing # Bars @ " " oc, ew
	Wet Well Base Reinforcing # Bars @ " " oc, ew
Wet Well Access Hatch Dimensions	
L	Access Hatch Overall Length
M	Access Hatch Clear Length
N	Access Hatch Overall Width
O	Access Hatch Clear Width
P	Access Hatch Offset
Pump Specifications	
	Pump Model Number
	Gallons per Minute (GPM)
	Total Dynamic Head (TDH)
	Horse Power (HP)
	Phase
	Voltage (V)
	Alarm Elevation
	Start Pump Elevation
	Pump Off Elevation

