

Plan View

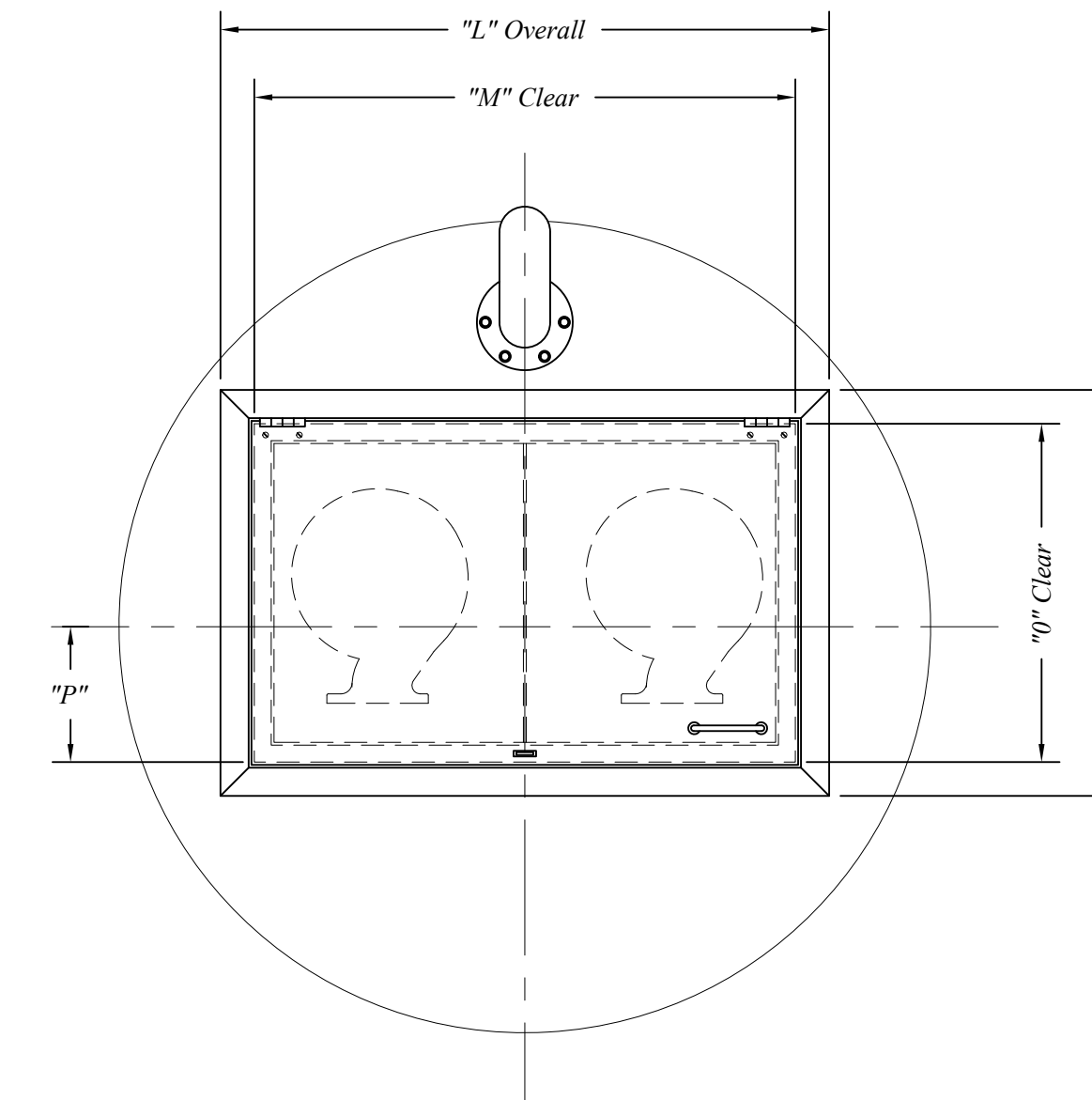

Profile View

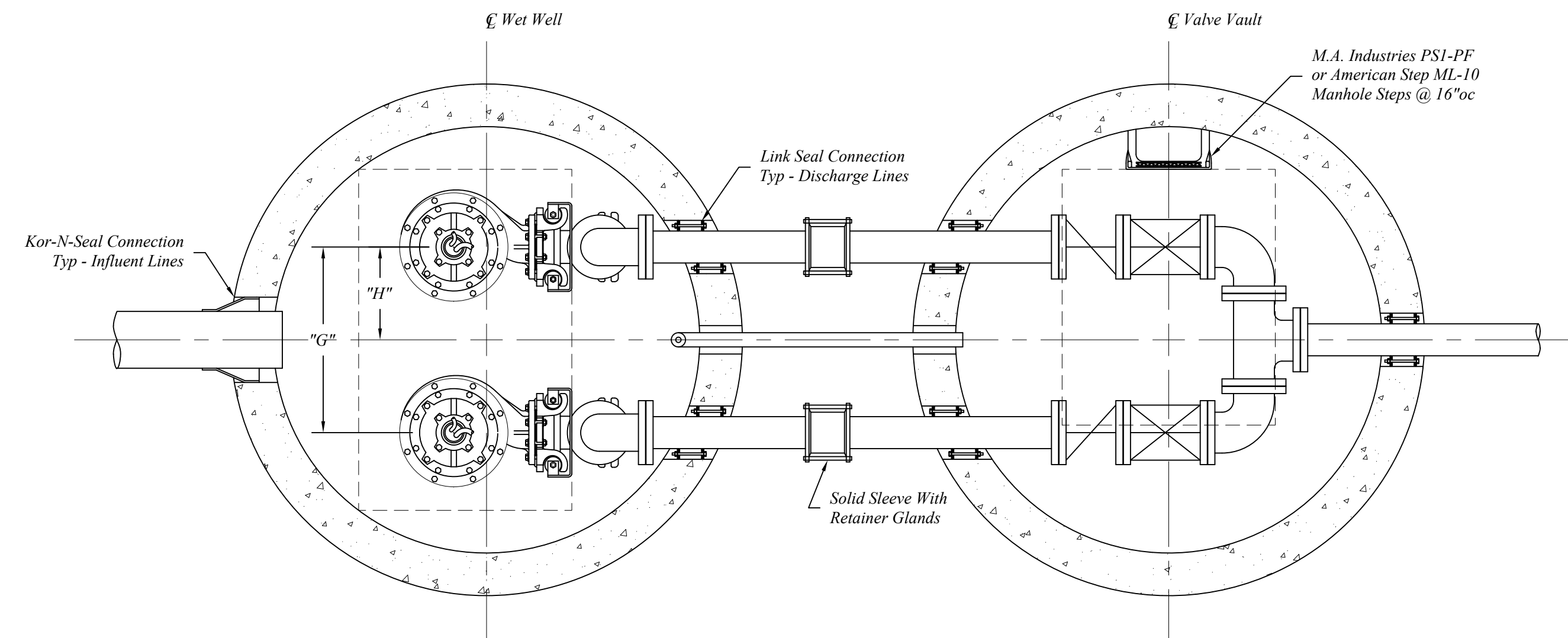
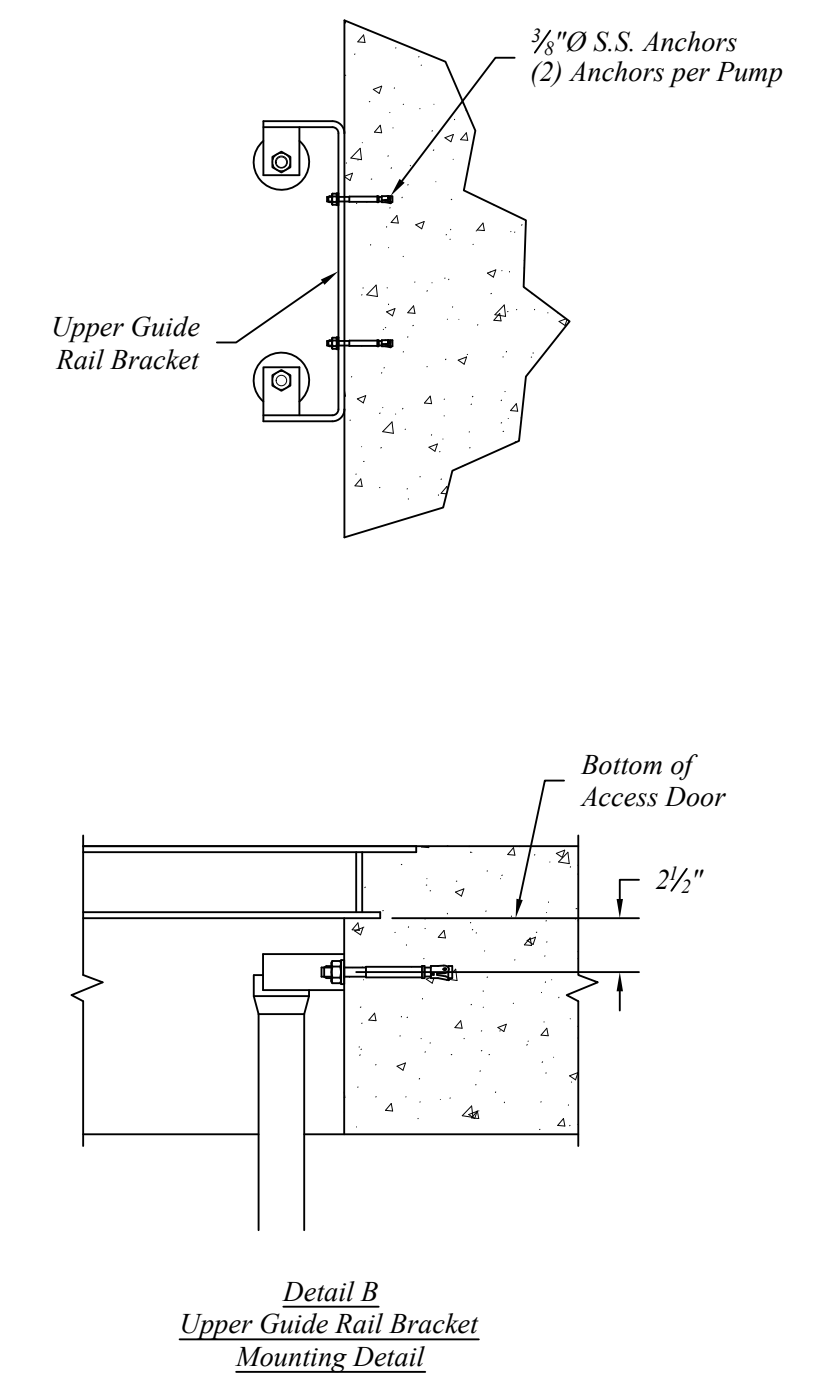
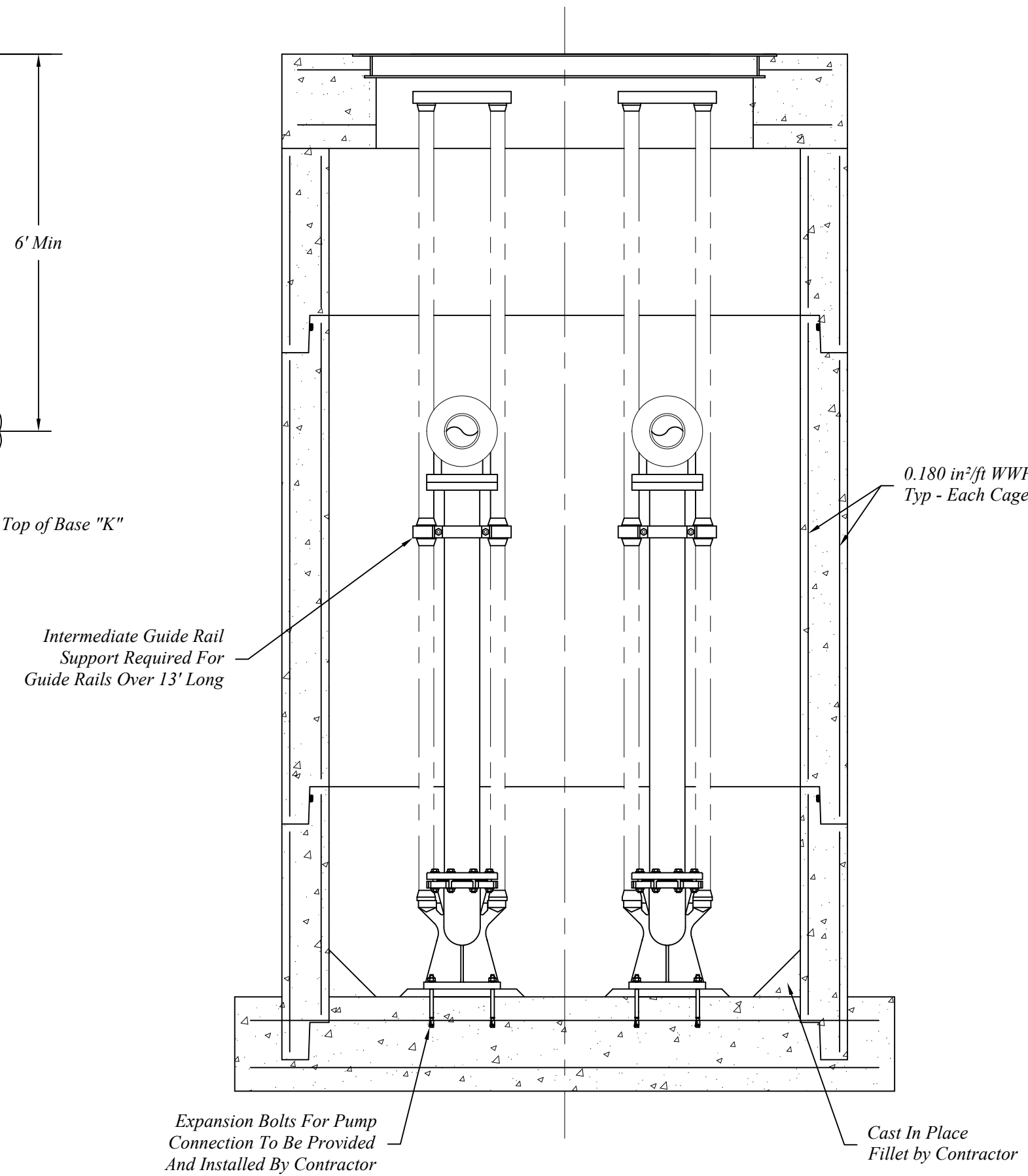
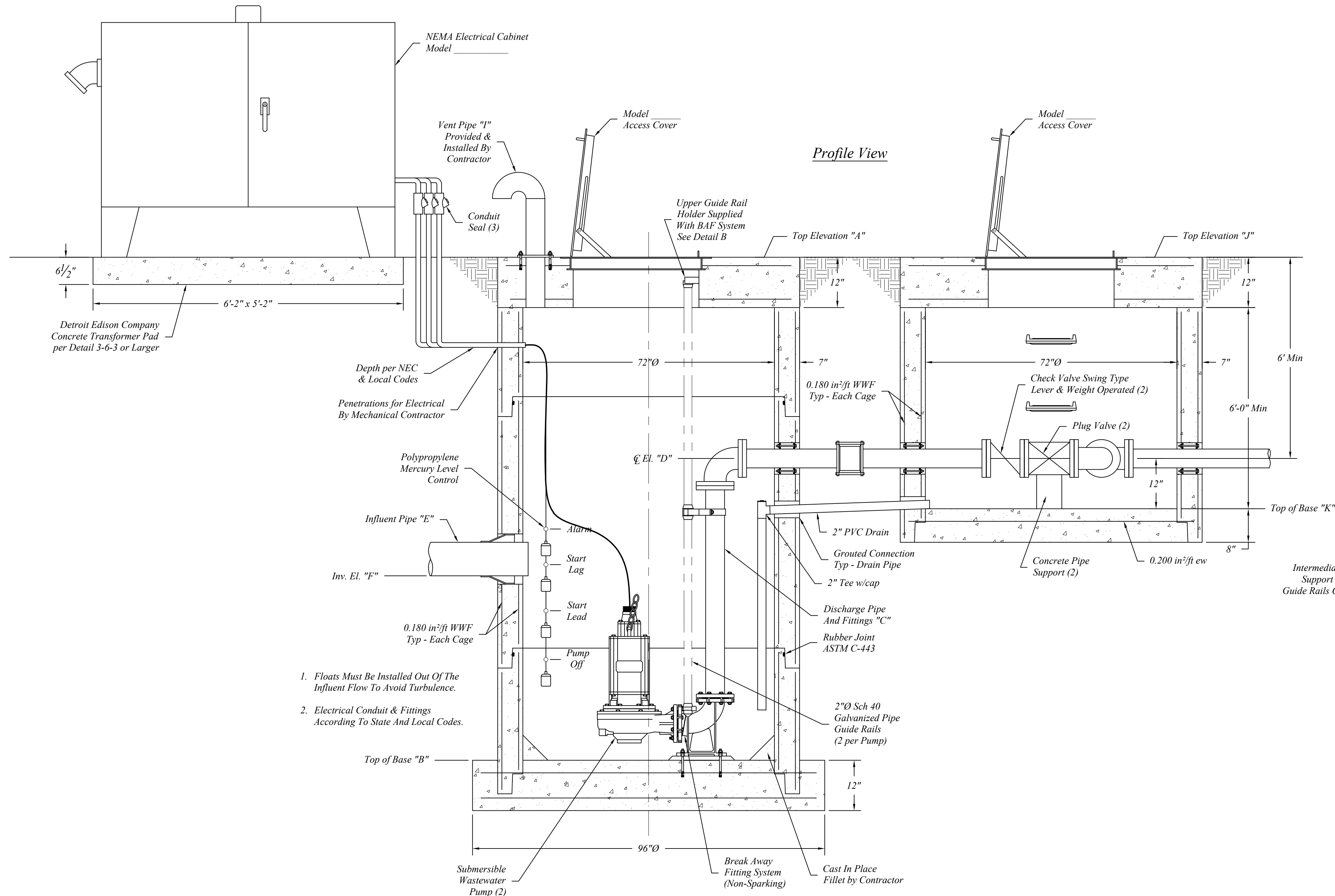

Precast Notes:
 Pump Station Sections To Be Manufactured To ASTM C-478 Specifications w/HIS-20 Loading.
 Manufactured as per Northern Concrete Pipe, Inc. (1.800.222.9918) or approved equal.
 Concrete: 4000 psi @ 28 Days.
 Reinforcement per ASTM A-615 & A-496.

Wet Well Dimensions	
A	Top of Cover Elevation
B	Top of Base Elevation
C	Discharge Pipe Diameter
D	Discharge Pipe ϕ Elevation
E	Influent Pipe Diameter
F	Influent Pipe Inv. Elevation
G	Discharge Line Spacing
H	Discharge Line Offset
I	Vent Pipe Diameter
Wet Well Cover Reinforcing # Bars @ " oc, ew	
Wet Well Base Reinforcing # Bars @ " oc, ew	
Valve Vault Dimensions	
J	Top of Cover Elevation
K	Top of Base Elevation
Valve Vault Cover Reinforcing # Bars @ " oc, ew	
Wet Well Access Hatch Dimensions	
L	Access Hatch Overall Length
M	Access Hatch Clear Length
N	Access Hatch Overall Width
O	Access Hatch Clear Width
P	Access Hatch Offset
Pump Specifications	
Pump Model Number	
Gallons per Minute (GPM)	
Total Dynamic Head (TDH)	
Horse Power (HP)	
Phase	
Voltage (V)	
Alarm Elevation	
Lag Pump Elevation	
Lead Pump Elevation	
Pump Off Elevation	

- Floats Must Be Installed Out Of The Influent Flow To Avoid Turbulence.
- Electrical Conduit & Fittings According To State And Local Codes.