

Interceptor/Grease Trap Sections To Be Manufactured per AASHTO 17th Ed. and ASTM Specifications w/HS-25 Loading and 0.0' to 3.0' of Earth Cover.

Concrete: 5000psi @ 28 Days

Reinforcement per ASTM A-615 & A-496.

Cover To Be Sealed w/1/2" EZ-Stik or Equal.

Pipe & Fittings For Inlets & Outlets Are Not Included.

Available Extra's:

- EJ Cast Iron Frames and Covers
- Concrete Grade Rings
- Fuel Resistant Butyl Sealant

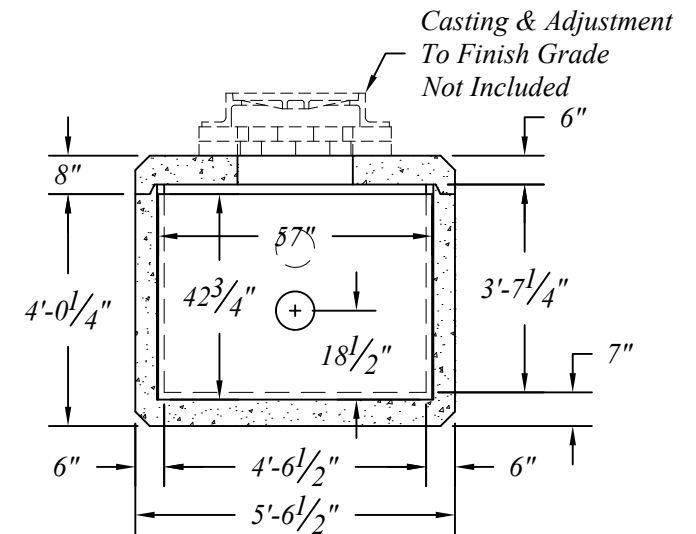
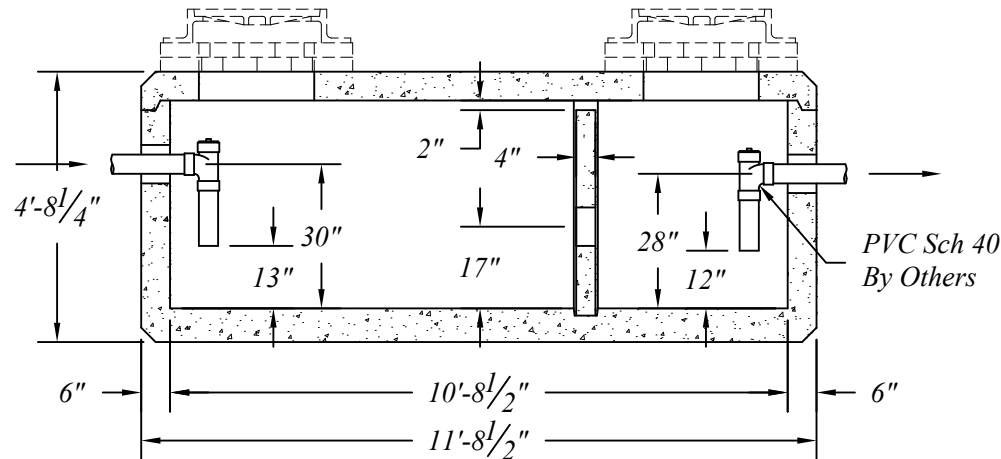

- Base - 15,000 #
- Weir - 850 #
- Cover - 4,700 #
- Total - 20,550 #



401 Kelton St Bay City, MI 48706		Proposed - 750 Gal. Traffic Interceptor/Grease Trap	
5281 Lansing Rd Charlotte, MI 48813	2701 Chicago Dr SW Wyoming, MI 49519		
4950 White Lake Rd Clarkston, MI 48346	3756 Centennial Rd Sylvania, OH 43560	Date 16 Sep 19	Revised
		Rev. No.	Drawn By BmG
		Scale NTS	08.01