

Casting & Adjustment
To Finish Grade
By Contractor

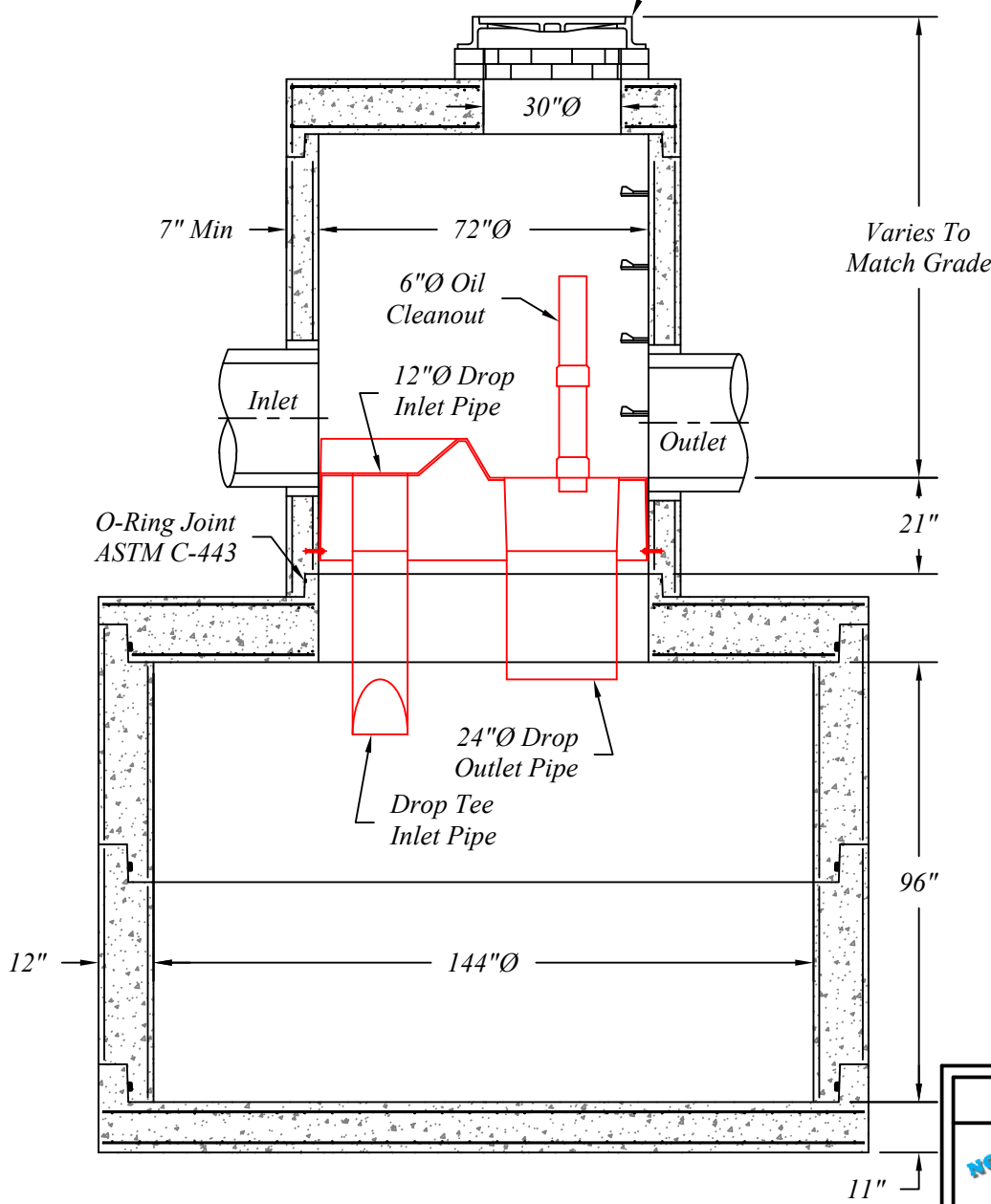

Section Thru Chamber

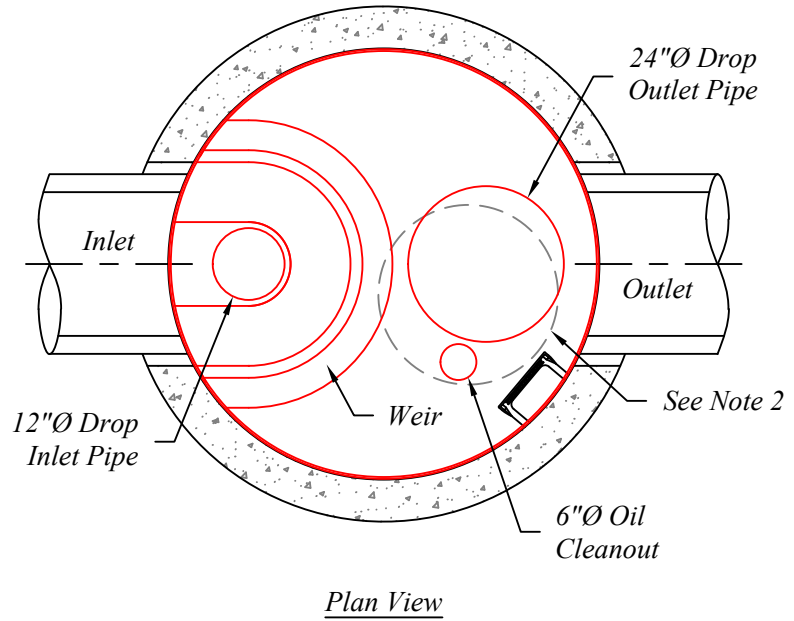

Plan View

- Notes:
1. Inlet & Outlet Connections To Be Grouted After Installation.
 2. The Cover Should Be Positioned Over The Inlet Drop Pipe And The Vent Pipe.
 3. The Stormceptor System Is Protected By One Or More Of The Following U.S. Patents: #4985148, #5498332, #5725760, #5753115, #5849181, #6068765, #6371690.
 4. Contact Northern Concrete Pipe, Inc. For Further Details Not Listed On This Drawing.

Typical Precast Concrete Stormceptor® STC 7200			
	401 Kelton St Bay City, MI 48706		Date 09 May 16
	5281 Lansing Rd Charlotte, MI 48813	2701 Chicago Dr SW Wyoming, MI 49519	Drawn By BmG
	4950 White Lake Rd Clarkston, MI 48346	3756 Centennial Rd Sylvania, OH 43560	Scale NTS
			09.09